

At what cost Quality?

Case Studies of Measurements that Facilitate the Optimization of Cost and Quality

Lori Balint, Technical Manager, Pulmac Instruments

Fiber Quality is important in paper quality, as a good quality fiber runs better on the paper machine and produces a good quality product. Due to production costs, however, there is often a trade off between cost and quality. A number of mills have found that measuring the zero and short span tensile strength in the pulping and papermaking process has reduced operational expenses while maintaining or increasing tonnage of high quality sellable paper.

This paper explains the measurement of zero and short span tensile strength. Several case studies are presented to explain how mills are balancing fiber qualities with cost, as well as improving customer satisfaction.

Measuring Fiber Quality

Method

Tensile strengths were measured with the Pulmac Z Span 3000. Test sheets were formed in the automated sheet former, then tested with the tester, with the jaws set at both zero span and short span. Twenty four to forty eight results were produced for each sample. These results were produced in about half an hour after taking the sample, making it possible for the mills to measure and control strength while in process. Measurement of zero and short span tensile strength in both the wet and dry conditions were used to calculate the following fiber quality indicators:

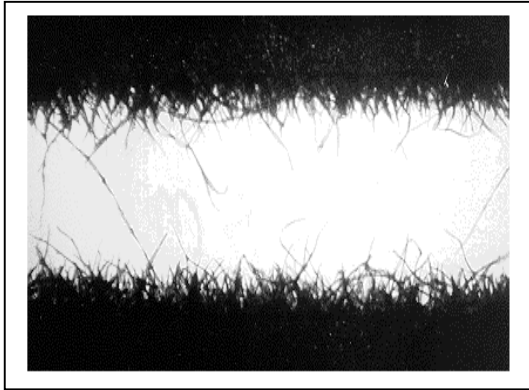

FS (fiber strength) – The zero span tensile strength is measured as a combination of the number of fibers that span both jaws, and the strength of each fiber. The number of fibers must be controlled through basis weight to provide an accurate measure of strength. This figure illustrates that when the jaws are at zero span, the majority of the fibers are broken, not pulled out.

Figure 1: Zero span tensile test – failure of fibers



L –the length is the ratio of tensile strength measured with the jaws at a short span (0.004 mm) to fiber strength. The short span tensile strength will be lower when the gap between the jaws is opened up, as fewer fibers will span both jaws. This number will decrease with decreasing fiber length.

B –The bonding potential is measured by the tensile strength of a dry sheet measured with the jaws at a short span, indexed to the tensile strength of a wet sheet measured with the jaws at short span. Measurement in the dry condition includes the energy to pull fibers apart (figure 2), while in the wet condition measures the energy to break the fibers.

Figure 2: Short span tensile test (dry)– failure of fibers and bonds

Balancing fiber qualities with cost

Fiber quality from the pulp mill can vary in strength, length and bonding characteristics. This variance can cost the mill in terms of the changes that need to be made to the stock to produce a uniform, high quality product, that runs well on the paper machine.

Southern NSSC/Medium mill – Increasing Average Machine Speed Without Sacrificing Quality.

An integrated medium mill was able to increase machine speed and improve quality, while minimizing the penalty of cost by measuring fiber qualities.

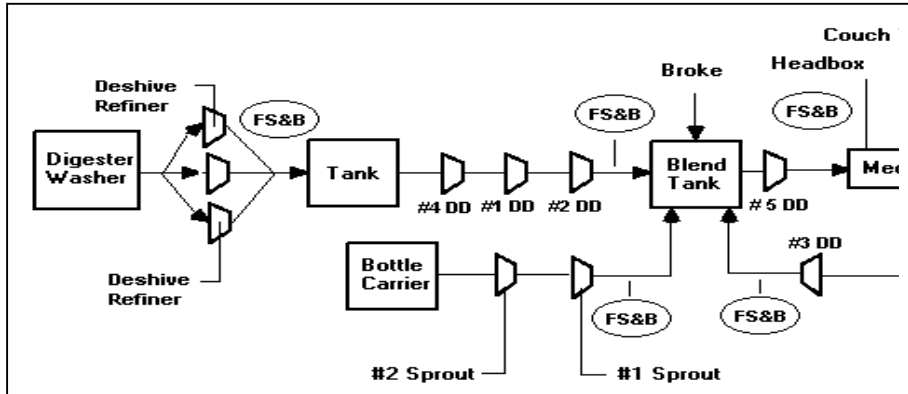

Diagram 1: Pulping and Paper Machine Schematic

They had to slow down their machine speed when test numbers fell. Increasing costly refiner energy was necessary to bring the numbers back up. The mill established the relationship of FS and B to the Ring Crush and Concorra test results (diagrams 2 & 3). These measurements were used in process to develop a baseline in terms of fiber properties, as shown in diagram 1. These measurements were then used to increase machine speed by locating and solving furnish problems that caused the low test numbers at the end of the machine.

In addition, the mill was able to use the “B” results to increase machine speed by 50 ft/min. This was accomplished by lowering refiner intensity. The average “B” numbers have increased by 16% as a result of a change that has only nominally increased energy consumption

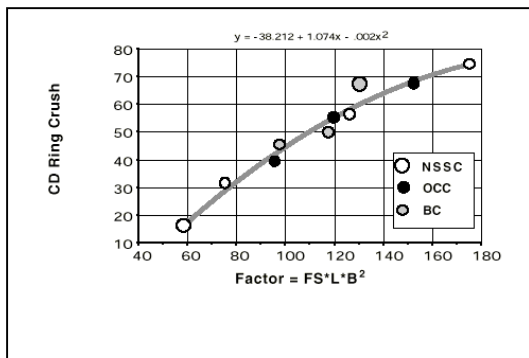

Diagram 2: FS, L B relationship to Ring Crush

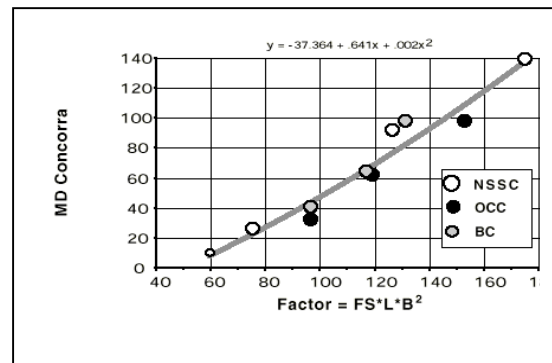

Diagram 3: FS, L B relationship to Concorra

Mid West Bleached Hardwood Fine Paper Mill – Reducing Paper Machine Breaks

This integrated fine paper mill faced the challenge of reducing downtime due to breaks on the paper machine. The mill first established a baseline of fiber quality in terms of FS, L and B. They then improved strength and were able to reduce the variation from the pulping process and variation from refining, which reduced variation to the paper machines (Table 1). They were also able to establish better broke management procedures to reduce pulp strength variability. These improvements allowed the mill to reduce breaks on the paper machine from 3 to 1.5 hours per day.

Sample Point	FS		L		B	
	average	cov*	average	cov*	average	cov*
Brown Stock Washer	86.0	4.1%	0.34	3.7%	1.84	3.3%
1st Stage Bleach Washer	85.0	5.0%	0.33	4.8%	1.81	6.0%
2nd Stage Bleach Washer	78.0	5.0%	0.32	4.9%	2.02	6.8%
3rd Stage Bleach Washer	76.0	4.4%	0.30	4.8%	2.14	5.7%
4th Stage Bleach Washer	74.0	4.3%	0.30	4.6%	2.13	5.0%
5PM Couch Tim Sample	69.8	6.3%	0.37	4.2%	2.61	9.0%

*cov=coefficient of variation (standard deviation/average)

Table 1: baseline fiber quality and increasing variation through process

Optimizing fiber qualities for Customer Satisfaction

There is a cost in customer satisfaction. The most notable event is the loss of a customer through poor quality. The most satisfying event is in helping a customer meet their goals through the quality of your fiber. The ability to measure FS, L and B characteristics in the pulp helps the mill to have a measurement they can control and to predict quality in the terms that customers understand.

Pacific Northwest Market Pulp Mill – Improving fiber qualities for reduced Customer Softwood Use

This mill produces semi bleached softwood Kraft for newsprint production. The customer had imposed cost constraints based on the tear strength of the pulp. It was advantageous for the mill to keep strength at a high level to improve profitability. It was equally advantages for the customer to receive higher strength pulp, as this would enable them to reduce the amount of softwood Kraft. Most mills asses the reduction of Kraft in their process as worth about 1 million dollars per percentage point.

The first step was to put into place a prediction of tear strength from fiber strength. This mill consistently measures good correlation between tear strength and fiber strength, as described by a correlation coefficient of 0.85.

After determining the cost structure of three different levels of fiber strength, the mill worked on understanding the variables in the pulp mill that effected strength. The operators monitored fiber strength from their DCS consol in the control room. This enabled them to see how the changes they made in the process affected pulp strength. They described it as the only game left to them on their computers. Winning was simply a matter of producing fiber strength in the high quality range. This has enabled the mill to be the benchmark supplier to their customer. Over time, this mill’s customer has been able to relate decreased softwood use to the increasing fiber strength of the supplied pulp. Both the supplier and the customer have won in the quality vs. cost optimization.

Northern Coastal Market Pulp – Prediction of Breaking Length

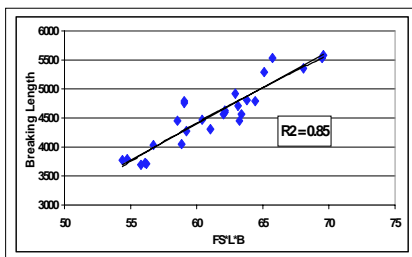

This market pulp mill provides a grade of blended pulps to a customer that was interested in the breaking length characteristics of the pulp. The mill needed an alternative to viscosity to measure the effect of blending on Breaking Length. They found that FS, L and B measurements on differing blends of pulp produced a linear relationship to breaking length. This allowed the mill to replace viscosity with tests that gave them more information, and was more credible than viscosity as it actually measures strength.

Diagram 4: The Breaking Length prediction from FS, L and B

Mid Atlantic Kraft/Linerboard– Reduced Downgraded Reels

This integrated mill produces white top linerboard. Low Mullen was not being predicted with in process measurements of viscosity, k number or freeness. When they started measuring zero and short span tensile strength in process, they found that it was a much better predictor of Mullen than either freeness or viscosity. This gave them a tool to measure and control Mullen strength in process.

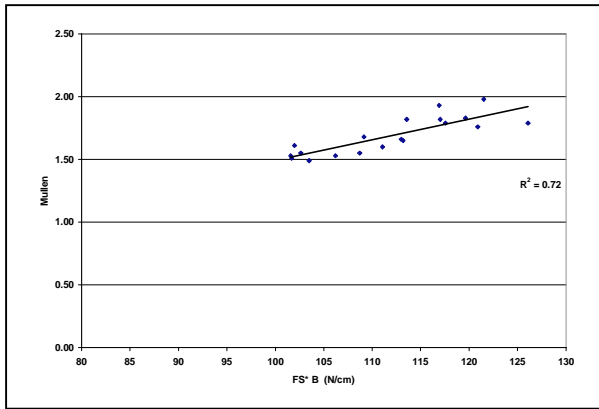

Diagram 4: Mullen prediction from FS and B

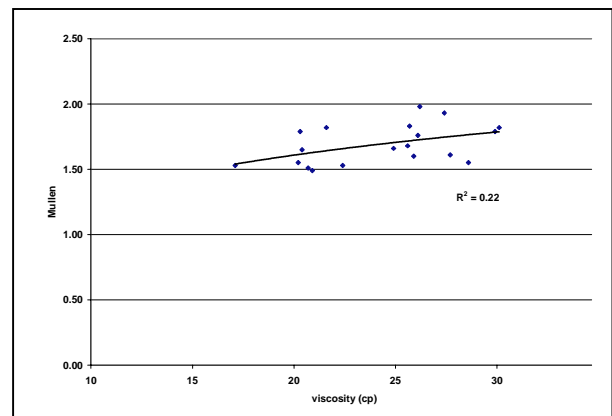

Diagram 5: Mullen prediction from Viscosity

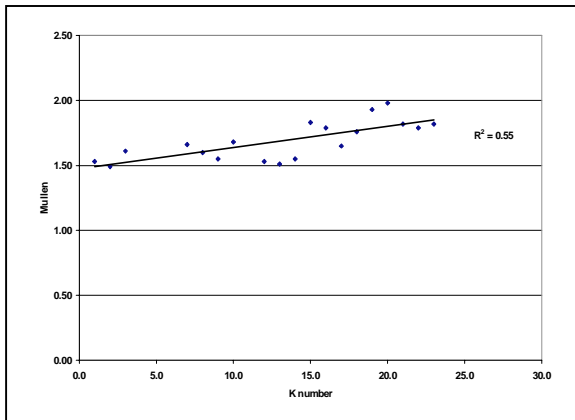

Diagram 6: Mullen prediction from freeness

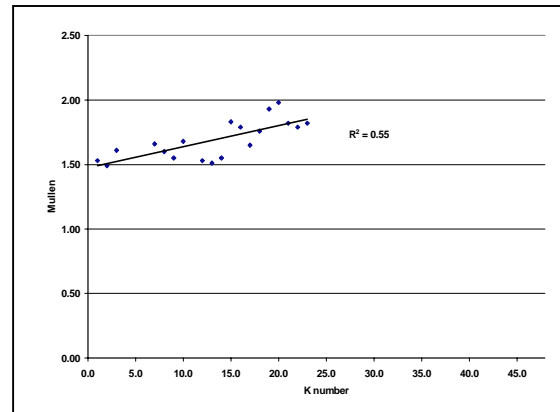

Diagram 7: Mullen prediction from K number

Conclusion

Measurement of fiber qualities FS, L and B has supported mill's efforts in reducing costs and optimizing product quality. Mills have found that the ability to measure the fiber quality of pulp in as little as a half an hour has allowed them to reduce bottlenecks around machine speed, increase machine uptime by reducing sheet breaks, reduce costs by reducing softwood use, optimize broke use, reduce downgraded products and engineer less costly processes while understanding how both fiber and product quality is affected.